

请详阅手册内容并善加保存
Please read and save this manual

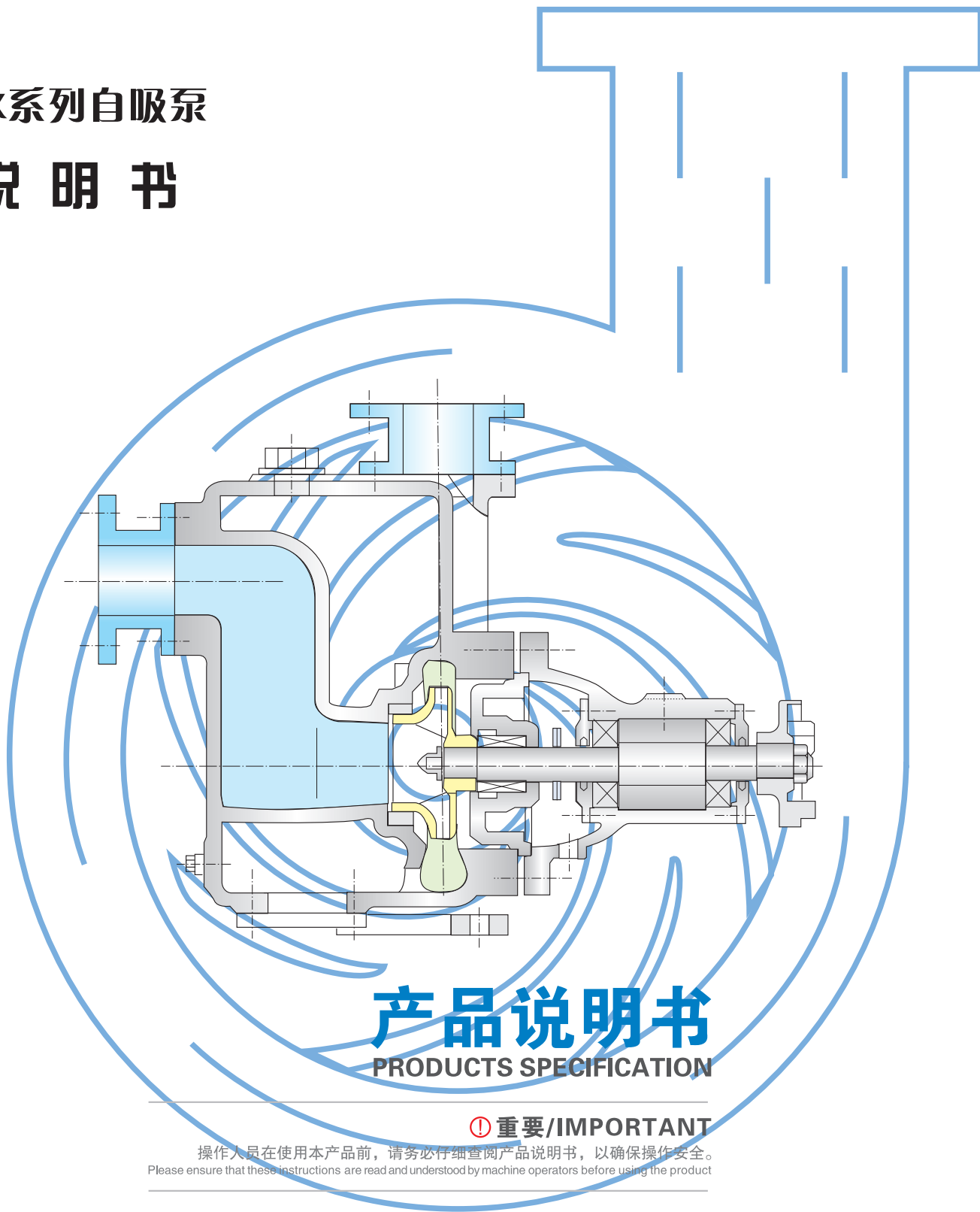

ZX系列自吸泵 说明书



产品说明书 PRODUCTS SPECIFICATION

① 重要/IMPORTANT

操作人员在使用本产品前，请务必仔细阅读产品说明书，以确保操作安全。
Please ensure that these instructions are read and understood by machine operators before using the product



上海河山泵业有限公司
SHANGHAI HESHAN PUMP CO., LTD.
电话:021-56557888 56557777

目录 CONTENTS

| | |
|---|----|
| 产品概述 | 01 |
| General | |
| 应用范围 | 01 |
| Range of application | |
| 型号意义 | 01 |
| Model meaning | |
| 结构说明 | 02 |
| About the structure | |
| 结构简图 | 03 |
| Brief diagram of structure | |
| 型谱图 | 03 |
| Spectrum of model | |
| 性能参数表 | 04 |
| Table of performance parameters | |
| 外形及安装尺寸图表 | 05 |
| Diagram and table of out-form and installation dimensions | |
| 泵的安装 | 06 |
| Pump installation | |
| 泵的使用 | 07 |
| Use of the pump | |
| 泵的维护和拆装 | 08 |
| Maintenance, disassembly and assembly of the pump | |
| 故障原因及排除方法 | 09 |
| Failures causes and troubleshooting | |

ZX系列自吸泵

产品概述 GENERAL

ZX系列自吸泵是采用ISO国际标准设计,并根据国内外有关技术资料经吸收、消化、改进后研制而成的节能泵类产品。该泵属自吸式离心泵,采用陶瓷环机械密封,使某些带有砂粒状的液体不会进入密封面而划伤,确保密封性能的稳定性。该泵具有结构紧凑、操作方便、运行平稳、维护容易、效率高、寿命长、自吸能力强等优点。管路中不需安装底阀,工作前只需保证泵体内储有一定量引液即可,因此既简化了管路系统,又改善了劳动条件。

该泵根据不同的使用环境可配有Y系列普通电机、YB系列防爆电机。

ZX series self-suction pump is an energy saving pump designed with ISO international standard and developed through absorbing and improving the related technical data both at home and abroad and belongs to the self-suction centrifugal pump and uses the mechanical seal of a ceramic ring so as to resist any sandy liquid to go into the sealing face, preventing it from getting scratched. This pump holds the advantages of a compact structure, easy operation, stable movement, easy maintenance, high efficiency, long duration and strong self-suction capacity and, as no foot valve is needed to be mounted on the pipeline and only a certain amount of leading liquid is required to be filled into the pump before work, improves the work condition while simplifying the pipeline system.

This pump can be equipped with either Y series common motor or YB series explosion-proof one upon the different surroundings of use.

应用范围 RANGE OF APPLICATION

- 1、适用于城市环保、建筑、消防、化工、制药、染料、印染、酿造、电力、电镀、造纸、工矿冲洗、设备冷却等。
- 2、装上摇臂式喷头,又可将水冲到空中后,再散成细雨滴进行喷雾,是农场、苗圃、果园、茶园的良好机具。
- 3、适用于清水、海水及带有酸、碱度的化工介质液体和带有一般糊状的浆料(介质粘度 ≤ 100 厘珀、含固量可达30%以下)。
- 4、可和任何型号、规格的压滤机配套使用,是将浆料送给压滤机进行压滤的最理想配套泵种。

- 1.Suitable for city environmental protection, construction, fire fighting, chemical industry, pharmacy, dyes, dyeing, brewing, electric power, electric plating, paper-making, industrial and mineral rinse, equipment cooling and so on.
- 2.This pump, when mounted with a shaking arm shower, can have the water burst into air and then scattered in a thin drop for spraying, useful to a farm, nursery, orchard and tee plantation.
- 3.Suitable for pure water, sea water, the chemical media of an acid and alkaline degree and the pulpy material of a general pasty state. (medium viscosity ≤ 100 cP, solid content below 30%).
- 4.This pump can work together with a pressure filter of any model and specification and is the most ideal matching pump to send pulpy materials to the said filter for pressure filtering.

型号意义 MODEL MEANING

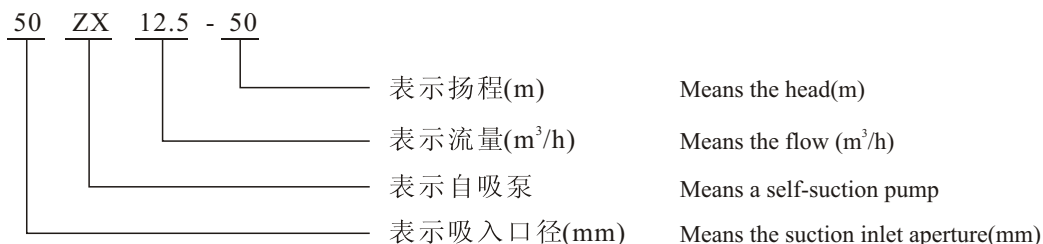

结构说明 ABOUT THE STRUCTURE

该泵均采用轴向回液的泵体结构。泵体由吸入室、储液室、涡卷室、回液孔、气液分离室等组成，泵正常启动后，叶轮将吸入室所存的液体及吸入管路中的空气一起吸入，并在叶轮内部得以完全混合，在离心力的作用下，液体夹带着气体向涡卷室外缘流动，在叶轮的外缘上形成有一定厚度的白色泡沫带及高速旋转液环。气液混合体通过扩散管进入气液分离室。此时，由于流速突然降低，较轻的气体从混合气液中被分离出来，气体通过泵体吐出口继续上升排出。排气后的液体回到储液室，并由回流孔再次进入叶轮，与叶轮内部从吸入管路中吸入的气体再次混合，在高速旋转的叶轮作用下，又流向叶轮外缘……随着这个过程周而复始地进行下去，吸入管路中的空气不断减少，直到吸尽气体，完成自吸过程，泵便投入正常作业。因为该泵具有这种独特的排气能力，所以此泵能输送含有气体的液体，无需安装底阀，使用在油轮上时具有良好的扫舱功能。

在一些砂的轴承体底部还设有冷却室。当轴承发热引起轴承体温升超过 70°C 时，可在冷却室处通过任意一只冷却液管接头，注入冷却液循环冷却。泵内部防止液体由高压区向低压区泄漏的密封机构是前后密封环，前密封环装在泵体上，后密封环装在轴承体上，当泵经长期运转密封环磨损到一定程度，并影响到泵的效率 and 自吸性能时，应给予更换。

This pump casing consists of a suck-in room, a liquid storing room, a scroll room, a liquid back hole, an air-liquid separating room etc. and holds an axially-liquid-back structure. After the pump is normally started, the impeller sucks in the all liquid inside of the suck-in room and the air inside of the pipeline and gets them completely mixed inside of it, then, under the action of the centrifugal force, the liquid, carrying the air, flows towards the outer edge of the scroll room and, on the outer edge of the impeller, a white foam band of a certain thickness and a quickly rotating liquid ring are formed. The air-liquid mixture gets into the air-liquid separating room through the expanding pipe and, as the flow-rate is abruptly lowered thereafter, the lighter air is separated from the mixture and rises through the vomit port of the pump casing and is exhausted therefrom. The liquid with the air off returns to the liquid storing room and gets into the impeller again through the liquid back hole, where it is mixed again with the air sucked in from the suck-in pipeline and, under the action of the quickly rotating impeller, flows towards the outer edge of the impeller again …… along with the repeated process, the air in the suck-in pipeline is continually reduced till being sucked up, the self-suction process ends and the pump gets into the normal work. This unique exhaust capacity makes the pump able to transport the air-contained liquid without a foot valve mounted and of a good cabin cleaning function when used on an oil ship.

There is a cooling room on the bottom of the bearing body with some pumps and, when the bearing body's temperature rise is over 70°C with the bearing heated, the cooling liquid can be injected in through any one of the cooling liquid unions in the cooling room for cycled cooling. The sealing mechanism inside of the pump used to prevent the liquid from leaking from the high pressure area to the low one is the front and rear seal rings, the front ring is mounted on the pump casing and the rear one on the bearing body. When the seal ring gets worn out to a certain extent after a long time work of the pump and thus affecting both efficiency and self-suction property of it, it should be replaced.

ZX系列自吸泵

结构简图 BRIEF DIAGRAM OF STRUCTURE

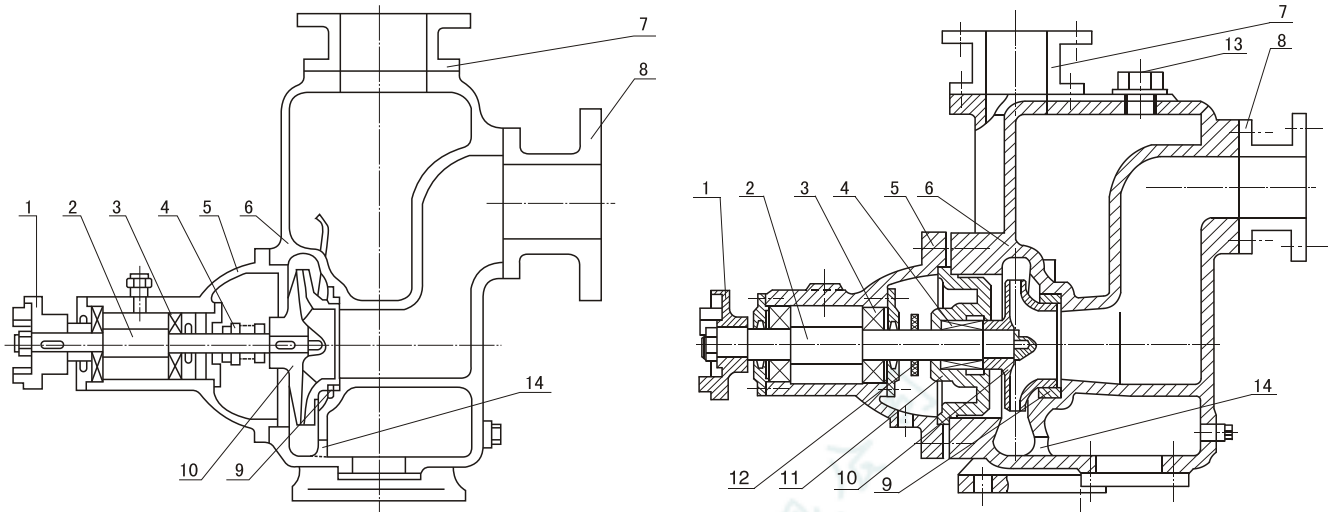

| | | | | | | | | | | | | | |
|---|-------------------|---|-------------------------|----|----------------|----|-------------------------|----|---------------------|----|----------------------------|----|-------------------------|
| 1 | 联轴器 Clutch | 2 | 泵轴 Pump shaft | 3 | 轴承 Bearing | 4 | 机械密封 Mechanical seal | 5 | 轴承体 Bearing body | 6 | 泵壳 Pump casing | 7 | 出口座 Outlet seat |
| 8 | 进口座 Inlet seat | 9 | 前密封环 Front seal ring | 10 | 叶轮 Impeller | 11 | 后盖 Rear cover | 12 | 挡水圈 Baffle ring | 13 | 加液孔 Liquid filling hole | 14 | 回液孔 Liquid back hole |

型谱图 SPECTRUM OF MODEL

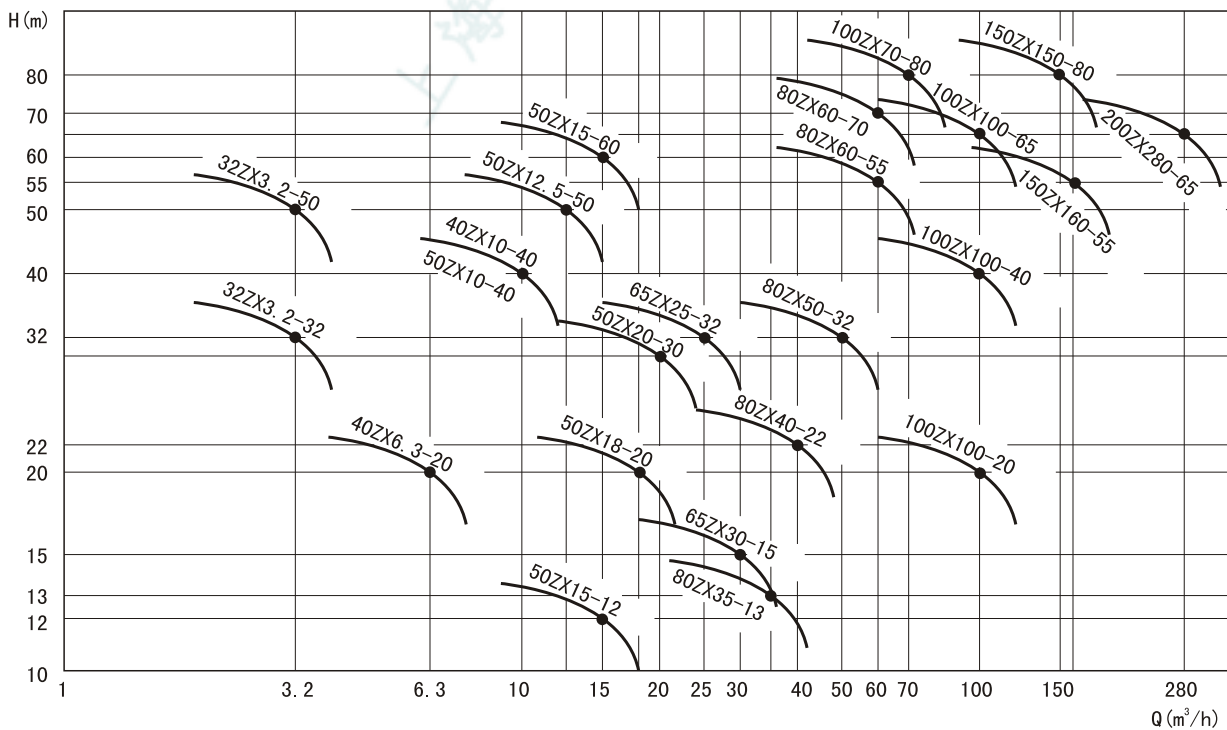

性能参数表 TABLE OF PERFORMANCE PARAMETERS

| 序号 No. | 型号 Type | 口径 Caliber (mm) | 流量 Flow (m³/h) | 扬程 Head (m) | 功率 Power (kw) | 转速 Speed (r/min) | 自吸高度 Self-priming height |
|--------|-------------|-----------------|----------------|-------------|---------------|------------------|--------------------------|
| 1 | 25ZX3.2-20 | 25 | 3.2 | 20 | 1.1 | 2900 | 6.5 |
| 2 | 25ZX3.2-32 | 25 | 3.2 | 32 | 1.5 | 2900 | 6.5 |
| 3 | 32ZX3.2-20 | 32 | 3.2 | 20 | 1.1 | 2900 | 6.5 |
| 4 | 32ZX3.2-32 | 32 | 3.2 | 32 | 1.5 | 2900 | 6.5 |
| 5 | 32ZX3.2-50 | 32 | 3.2 | 50 | 3 | 2900 | 6.5 |
| 6 | 40ZX6.3-20 | 40 | 6.3 | 20 | 1.5 | 2900 | 6.5 |
| 7 | 40ZX6.3-32 | 40 | 6.3 | 32 | 2.2 | 2900 | 6.5 |
| 8 | 40ZX10-40 | 40 | 10 | 40 | 4 | 2900 | 6.5 |
| 9 | 40ZX6.3-50 | 40 | 6.3 | 50 | 4 | 2900 | 6.5 |
| 10 | 50ZX15-12 | 50 | 15 | 12 | 1.5 | 2900 | 6.5 |
| 11 | 50ZX18-20 | 50 | 18 | 20 | 2.2 | 2900 | 6.5 |
| 12 | 50ZX12.5-32 | 50 | 12.5 | 32 | 3 | 2900 | 6.5 |
| 13 | 50ZX12.5-40 | 50 | 12.5 | 40 | 4 | 2900 | 6.5 |
| 14 | 50ZX12.5-50 | 50 | 12.5 | 50 | 5.5 | 2900 | 6.5 |
| 15 | 50ZX20-30 | 50 | 20 | 30 | 4 | 2900 | 6.5 |
| 16 | 50ZX14-35 | 50 | 14 | 35 | 4 | 2900 | 6.5 |
| 17 | 50ZX10-40 | 50 | 10 | 40 | 4 | 2900 | 6.5 |
| 18 | 50ZX15-60 | 50 | 15 | 60 | 7.5 | 2900 | 6.5 |
| 19 | 50ZX20-75 | 50 | 20 | 75 | 11 | 2900 | 6.5 |
| 20 | 65ZX30-15 | 65 | 30 | 15 | 3 | 2900 | 6.5 |
| 21 | 65ZX25-32 | 65 | 25 | 32 | 5.5 | 2900 | 6 |
| 22 | 65ZX25-50 | 65 | 25 | 50 | 7.5 | 2900 | 6 |
| 23 | 65ZX25-70 | 65 | 25 | 70 | 15 | 2900 | 6 |
| 24 | 80ZX35-13 | 80 | 35 | 13 | 3 | 2900 | 6 |
| 25 | 80ZX43-17 | 80 | 43 | 17 | 4 | 2900 | 6 |
| 26 | 80ZX40-22 | 80 | 40 | 22 | 5.5 | 2900 | 6 |

| 序号 No. | 型号 Type | 口径 Caliber (mm) | 流量 Flow (m³/h) | 扬程 Head (m) | 功率 Power (kw) | 转速 Speed (r/min) | 自吸高度 Self-priming height |
|--------|-------------|-----------------|----------------|-------------|---------------|------------------|--------------------------|
| 27 | 80ZX50-20 | 80 | 50 | 20 | 5.5 | 2900 | 6 |
| 28 | 80ZX50-25 | 80 | 50 | 25 | 7.5 | 2900 | 6 |
| 29 | 80ZX50-32 | 80 | 50 | 32 | 7.5 | 2900 | 6 |
| 30 | 80ZX50-40 | 80 | 50 | 40 | 11 | 2900 | 6 |
| 31 | 80ZX60-55 | 80 | 60 | 55 | 18.5 | 2900 | 6 |
| 32 | 80ZX60-70 | 80 | 60 | 70 | 22 | 2900 | 6 |
| 33 | 100ZX80-20 | 100 | 80 | 20 | 11 | 2900 | 6 |
| 34 | 100ZX100-20 | 100 | 100 | 20 | 11 | 2900 | 6 |
| 35 | 100ZX100-32 | 100 | 100 | 32 | 15 | 2900 | 6 |
| 36 | 100ZX100-40 | 100 | 100 | 40 | 18.5 | 2900 | 6 |
| 37 | 100ZX100-50 | 100 | 100 | 50 | 22 | 2900 | 6 |
| 38 | 100ZX100-65 | 100 | 100 | 65 | 30 | 2900 | 6 |
| 39 | 100ZX70-75 | 100 | 70 | 75 | 30 | 2900 | 6 |
| 40 | 150ZX180-28 | 150 | 180 | 28 | 30 | 2900 | 6 |
| 41 | 150ZX170-55 | 150 | 170 | 55 | 45 | 2900 | 5 |
| 42 | 150ZX170-65 | 150 | 170 | 65 | 55 | 2900 | 5 |
| 43 | 150ZX160-80 | 150 | 160 | 80 | 55 | 2900 | 5 |
| 44 | 200ZX400-32 | 200 | 400 | 32 | 55 | 1450 | 5 |
| 45 | 200ZX280-63 | 200 | 280 | 63 | 90 | 1450 | 5 |
| 46 | 200ZX350-65 | 200 | 350 | 65 | 110 | 1450 | 5 |
| 47 | 250ZX550-32 | 250 | 550 | 32 | 75 | 1450 | 5 |
| 48 | 250ZX400-50 | 250 | 400 | 50 | 90 | 1450 | 5 |
| 49 | 250ZX450-55 | 250 | 450 | 55 | 110 | 1450 | 5 |
| 50 | 300ZX600-32 | 300 | 600 | 32 | 90 | 1450 | 5 |
| 51 | 300ZX500-50 | 300 | 500 | 50 | 110 | 1450 | 5 |
| 52 | 300ZX550-55 | 300 | 550 | 55 | 132 | 1450 | 5 |

外形及安装尺寸图 DIAGRAM OF OUT-FORM AND INSTALLATION DIMENSIONS

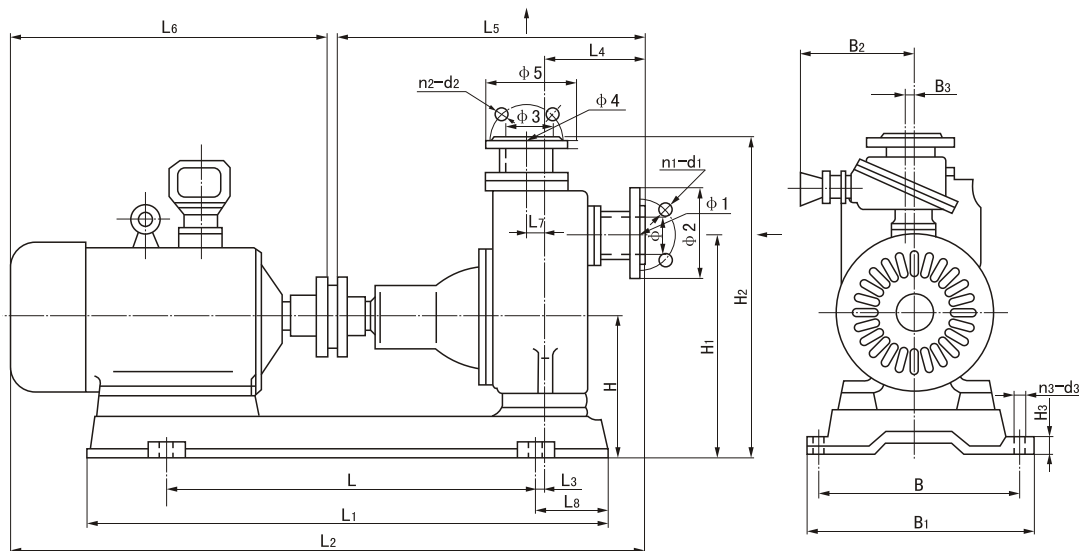

ZX系列自吸泵

外形及安装尺寸表 TABLE OF OUT-FORM AND INSTALLATION DIMENSIONS

| 型号 Type | 电机 Motor | | L | L1 | L2 | L3 | L4 | L5 | L6 | L7 | L8 | δ | H | H1 | H2 | H3 | B | B1 | B2 | B3 | φ | φ1 | φ2 | φ3 | φ4 | φ5 | n1-d1 | n2-d2 | n3-d3 |
|-------------|------------|---------------------|------|------|------|------|-----|------|------|----|-----|---|-----|------|------|----|-----|-----|-----|-----|-----|-----|-----|-----|-----|-----|-------|-------|-------|
| | 型号 Type | 功率 Power (kW) | | | | | | | | | | | | | | | | | | | | | | | | | | | |
| 25ZX3.2-20 | Y801-2 | 0.75 | 320 | 615 | 791 | 75 | 155 | 450 | 339 | 38 | 155 | 2 | 195 | 300 | 436 | 20 | 280 | 320 | 225 | 4 | 25 | 75 | 100 | 25 | 75 | 100 | 4-12 | 4-12 | 4-14 |
| 25ZX3.2-32 | Y802-2 | 1.1 | 350 | 580 | 732 | 45 | 125 | 391 | 339 | 重合 | 115 | 2 | 200 | 320 | 450 | 15 | 300 | 330 | 225 | 重合 | 25 | 75 | 100 | 25 | 75 | 100 | 4-12 | 4-12 | 4-12 |
| 32ZX3.2-20 | Y801-2 | 0.75 | 320 | 615 | 791 | 75 | 155 | 450 | 339 | 38 | 155 | 2 | 195 | 300 | 436 | 20 | 280 | 320 | 225 | 4 | 32 | 100 | 120 | 32 | 100 | 120 | 4-12 | 4-12 | 4-12 |
| 32ZX3.2-32 | Y802-2 | 1.1 | 350 | 580 | 732 | 45 | 125 | 391 | 339 | 38 | 115 | 2 | 200 | 320 | 450 | 15 | 300 | 330 | 225 | 4 | 32 | 100 | 120 | 32 | 100 | 120 | 4-12 | 4-12 | 4-12 |
| 32ZX3.2-50 | Y100L-2 | 3 | 350 | 580 | 732 | 45 | 125 | 391 | 339 | 38 | 115 | 2 | 200 | 320 | 450 | 15 | 300 | 330 | 225 | 4 | 32 | 10 | 120 | 32 | 100 | 120 | 4-12 | 4-12 | 4-12 |
| 40ZX6.3-20 | Y802-2 | 1.1 | 320 | 615 | 791 | 75 | 155 | 450 | 339 | 38 | 150 | 2 | 195 | 300 | 436 | 20 | 280 | 320 | 225 | 重合 | 40 | 100 | 130 | 32 | 100 | 120 | 4-14 | 4-14 | 4-14 |
| 40ZX6.3-32 | Y90L-2 | 2.2 | 500 | 795 | 780 | 33 | 173 | 515 | 470 | 38 | 150 | 3 | 195 | 380 | 436 | 20 | 280 | 320 | 225 | 4 | 40 | 100 | 130 | 32 | 100 | 120 | 4-14 | 4-14 | 4-14 |
| 40ZX10-40 | Y112M-2 | 4 | 500 | 795 | 990 | 33 | 173 | 515 | 470 | 重合 | 145 | 3 | 220 | 380 | 530 | 30 | 370 | 410 | 225 | 重合 | 40 | 100 | 130 | 40 | 110 | 130 | 4-14 | 4-14 | 4-14 |
| 40ZX6.3-50 | Y112M-2 | 4 | 385 | 660 | 770 | 33 | 173 | 515 | 470 | 38 | 145 | 3 | 220 | 280 | 530 | 30 | 370 | 410 | 225 | 4 | 40 | 100 | 130 | 40 | 110 | 130 | 4-14 | 4-14 | 4-14 |
| 50ZX15-12 | Y90S-2 | 1.5 | 320 | 615 | 777 | 80 | 131 | 406 | 369 | 重合 | 150 | 2 | 185 | 305 | 436 | 20 | 280 | 320 | 225 | 4.5 | 50 | 110 | 140 | 50 | 110 | 140 | 4-14 | 4-14 | 4-14 |
| 50ZX18-20 | Y90L-2 | 2.2 | 440 | 680 | 833 | 25 | 152 | 436 | 394 | 重合 | 120 | 3 | 193 | 323 | 475 | 25 | 320 | 360 | 225 | 7 | 50 | 110 | 140 | 50 | 110 | 140 | 4-14 | 4-14 | 4-14 |
| 50ZX12.5-32 | Y100L-2 | 3 | 440 | 680 | 837 | 50 | 143 | 445 | 440 | 重合 | 120 | 2 | 213 | 353 | 503 | 25 | 320 | 360 | 225 | 5 | 50 | 110 | 140 | 50 | 110 | 140 | 4-14 | 4-14 | 4-14 |
| 50ZX12.5-40 | Y112M-2 | 4 | 480 | 870 | 900 | 74 | 142 | 454 | 520 | 38 | 195 | 3 | 220 | 380 | 540 | 30 | 360 | 404 | 240 | 5 | 50 | 110 | 140 | 50 | 110 | 140 | 4-14 | 4-14 | 4-14 |
| 50ZX12.5-50 | Y132S1-2 | 5.5 | 480 | 870 | 977 | 74 | 142 | 454 | 520 | 重合 | 195 | 3 | 220 | 380 | 540 | 30 | 360 | 404 | 240 | 重合 | 50 | 110 | 140 | 50 | 110 | 140 | 4-14 | 4-14 | 4-18 |
| 50ZX20-30 | Y112M-2 | 4 | 500 | 795 | 990 | 33 | 173 | 515 | 470 | 重合 | 145 | 3 | 220 | 380 | 530 | 30 | 370 | 410 | 225 | 重合 | 50 | 110 | 140 | 50 | 110 | 140 | 4-14 | 4-14 | 4-14 |
| 50ZX14-35 | Y112M-2 | 4 | 500 | 795 | 990 | 33 | 173 | 515 | 470 | 重合 | 145 | 3 | 220 | 380 | 530 | 30 | 370 | 410 | 225 | 5 | 50 | 110 | 140 | 50 | 110 | 140 | 4-14 | 4-14 | 4-14 |
| 50ZX10-40 | Y112M-2 | 4 | 440 | 680 | 857 | 55 | 143 | 445 | 470 | 重合 | 120 | 2 | 213 | 353 | 503 | 25 | 320 | 360 | 225 | 5 | 50 | 110 | 140 | 50 | 110 | 140 | 4-14 | 4-14 | 4-14 |
| 50ZX15-60 | Y132S2-2 | 7.5 | 510 | 870 | 1064 | 60.5 | 230 | 541 | 520 | 重合 | 180 | 3 | 270 | 440 | 600 | 25 | 380 | 410 | 240 | 8 | 50 | 125 | 160 | 50 | 125 | 160 | 4-18 | 4-18 | 4-18 |
| 50ZX20-75 | Y160M1-2 | 11 | 600 | 1000 | 1212 | 87.5 | 230 | 541 | 668 | 重合 | 200 | 3 | 280 | 450 | 630 | 25 | 415 | 445 | 240 | 8 | 50 | 125 | 160 | 50 | 125 | 160 | 4-18 | 4-18 | 4-18 |
| 65ZX30-15 | Y100L-2 | 3 | 440 | 680 | 864 | 36 | 135 | 421 | 440 | 重合 | 120 | 3 | 203 | 333 | 473 | 25 | 320 | 360 | 225 | 8 | 65 | 130 | 160 | 50 | 110 | 140 | 4-14 | 4-14 | 4-14 |
| 65ZX25-32 | Y132S1-2 | 5.5 | 480 | 870 | 989 | 63 | 148 | 466 | 520 | 重合 | 195 | 3 | 220 | 370 | 530 | 30 | 360 | 404 | 240 | 8 | 65 | 130 | 160 | 50 | 110 | 140 | 4-18 | 4-14 | 4-18 |
| 65ZX25-50 | Y132S2-2 | 7.5 | 520 | 900 | 1020 | 63 | 148 | 466 | 520 | 38 | 195 | 3 | 220 | 370 | 530 | 30 | 360 | 404 | 240 | 8 | 65 | 145 | 145 | 50 | 125 | 165 | 4-18 | 4-18 | 4-18 |
| 65ZX25-70 | Y160M2-2 | 15 | 600 | 1000 | 1212 | 90 | 230 | 54 | 668 | 38 | 200 | 3 | 280 | 450 | 630 | 25 | 415 | 445 | 240 | 8 | 65 | 145 | 145 | 50 | 125 | 165 | 4-18 | 4-18 | 4-18 |
| 80ZX35-13 | Y100L-2 | 3 | 440 | 680 | 884 | 42 | 145 | 441 | 440 | 重合 | 120 | 3 | 203 | 343 | 493 | 25 | 320 | 360 | 225 | 9 | 80 | 150 | 185 | 65 | 130 | 160 | 4-18 | 4-14 | 4-14 |
| 80ZX43-17 | Y112M-2 | 4 | 500 | 795 | 949 | 25 | 152 | 476 | 470 | 重合 | 145 | 3 | 220 | 370 | 530 | 30 | 370 | 410 | 225 | 12 | 80 | 150 | 185 | 65 | 130 | 160 | 4-18 | 4-14 | 4-14 |
| 80ZX40-22 | Y132S1-2 | 5.5 | 480 | 870 | 999 | 61 | 152 | 476 | 520 | 重合 | 195 | 3 | 220 | 370 | 530 | 30 | 360 | 404 | 240 | 12 | 80 | 150 | 185 | 65 | 130 | 160 | 4-18 | 4-14 | 4-14 |
| 80ZX50-20 | Y132S1-2 | 5.5 | 480 | 870 | 999 | 61 | 152 | 476 | 520 | 重合 | 195 | 3 | 220 | 370 | 530 | 30 | 360 | 404 | 240 | 12 | 80 | 150 | 185 | 65 | 130 | 160 | 4-18 | 4-14 | 4-14 |
| 80ZX50-25 | Y132S2-2 | 7.5 | 480 | 870 | 1080 | 70.5 | 270 | 557 | 520 | 70 | 195 | 3 | 225 | 406 | 595 | 30 | 360 | 404 | 240 | 重合 | 80 | 160 | 195 | 80 | 160 | 195 | 4-18 | 4-18 | 4-18 |
| 80ZX50-32 | Y132S2-2 | 7.5 | 480 | 870 | 1080 | 70.5 | 270 | 557 | 520 | 70 | 195 | 3 | 225 | 406 | 595 | 30 | 360 | 404 | 240 | 重合 | 80 | 160 | 195 | 80 | 160 | 195 | 4-18 | 4-18 | 4-18 |
| 80ZX50-40 | Y160M1-2 | 11 | 560 | 950 | 1140 | 70.5 | 270 | 557 | 520 | 70 | 195 | 3 | 225 | 406 | 595 | 30 | 360 | 404 | 240 | 重合 | 80 | 160 | 195 | 80 | 160 | 195 | 4-18 | 4-18 | 4-18 |
| 80ZX60-55 | Y160L-2 | 18.5 | 600 | 1025 | 1269 | 95 | 200 | 558 | 708 | 重合 | 200 | 3 | 280 | 450 | 655 | 25 | 415 | 445 | 240 | 10 | 80 | 160 | 195 | 80 | 160 | 195 | 4-18 | 4-18 | 4-18 |
| 80ZX60-70 | Y180M-2 | 22 | 730 | 1170 | 1404 | 38 | 211 | 656 | 745 | 重合 | 195 | 3 | 300 | 490 | 705 | 30 | 460 | 510 | 240 | 10 | 80 | 160 | 195 | 80 | 160 | 195 | 4-18 | 4-18 | 4-18 |
| 100ZX80-20 | Y132S2-2 | 7.5 | 600 | 940 | 1140 | 87.5 | 202 | 575 | 668 | 重合 | 200 | 3 | 260 | 420 | 590 | 30 | 415 | 445 | 240 | 重合 | 100 | 170 | 210 | 100 | 170 | 250 | 4-18 | 4-18 | 4-18 |
| 100ZX100-20 | Y160M1-2 | 11 | 600 | 1000 | 1246 | 87.5 | 202 | 575 | 668 | 重合 | 200 | 3 | 260 | 420 | 590 | 30 | 415 | 445 | 240 | 重合 | 100 | 170 | 210 | 100 | 170 | 250 | 4-18 | 4-18 | 4-18 |
| 100ZX100-32 | Y160M2-2 | 15 | 600 | 1100 | 1350 | 87.5 | 202 | 575 | 668 | 重合 | 200 | 3 | 260 | 420 | 590 | 30 | 415 | 445 | 240 | 重合 | 100 | 170 | 210 | 100 | 170 | 250 | 4-18 | 4-18 | 4-18 |
| 100ZX100-40 | Y180M-2 | 22 | 660 | 1060 | 1392 | 115 | 215 | 647 | 743 | 重合 | 200 | 2 | 320 | 490 | 710 | 25 | 460 | 510 | 240 | 12 | 100 | 170 | 210 | 100 | 170 | 210 | 8-18 | 8-18 | 4-18 |
| 100ZX100-50 | Y180M-2 | 22 | 660 | 1060 | 1392 | 115 | 215 | 647 | 743 | 重合 | 200 | 2 | 320 | 490 | 710 | 25 | 460 | 510 | 240 | 12 | 100 | 170 | 210 | 100 | 170 | 210 | 8-18 | 8-18 | 4-18 |
| 100ZX100-65 | Y200L1-2 | 30 | 780 | 1320 | 1566 | 116 | 230 | 743 | 820 | 重合 | 270 | 3 | 335 | 555 | 785 | 30 | 546 | 596 | 290 | 14 | 100 | 180 | 215 | 100 | 180 | 215 | 8-18 | 8-18 | 4-19 |
| 100ZX70-75 | Y200L1-2 | 30 | 780 | 1320 | 1566 | 116 | 230 | 743 | 820 | 重合 | 270 | 3 | 335 | 555 | 785 | 30 | 546 | 596 | 290 | 14 | 100 | 180 | 215 | 100 | 180 | 215 | 8-18 | 8-18 | 4-19 |
| 150ZX180-28 | Y200L1-2 | 30 | 780 | 1310 | 1550 | 130 | 230 | 950 | 830 | 70 | 320 | 3 | 350 | 650 | 960 | 30 | 580 | 630 | 290 | 30 | 150 | 240 | 285 | 150 | 240 | 285 | 8-22 | 8-22 | 8-22 |
| 150ZX170-55 | Y225M-2 | 45 | 780 | 1420 | 1650 | 150 | 250 | 950 | 830 | 70 | 320 | 3 | 350 | 650 | 960 | 30 | 580 | 630 | 290 | 30 | 150 | 240 | 285 | 150 | 240 | 285 | 8-22 | 8-22 | 8-22 |
| 150ZX170-65 | Y250M-2 | 55 | 905 | 1500 | 1780 | 150 | 250 | 950 | 830 | 70 | 320 | 3 | 350 | 650 | 960 | 30 | 580 | 630 | 290 | 30 | 150 | 240 | 285 | 150 | 240 | 285 | 8-22 | 8-22 | 8-22 |
| 150ZX160-80 | Y250M-2 | 55 | 905 | 1500 | 1780 | 150 | 250 | 950 | 830 | 70 | 320 | 3 | 350 | 650 | 960 | 30 | 580 | 630 | 290 | 30 | 150 | 240 | 285 | 150 | 240 | 285 | 8-22 | 8-22 | 8-22 |
| 200ZX400-32 | Y250M-2 | 55 | 900 | 1620 | 2083 | 165 | 470 | 1127 | 953 | 重合 | 360 | 3 | 440 | 800 | 1170 | 30 | 710 | 770 | 290 | 30 | 200 | 280 | 315 | 200 | 280 | 315 | 8-18 | 8-18 | 4-25 |
| 200ZX280-63 | Y280M-4 | 90 | 1000 | 1860 | 2242 | 210 | 430 | 1180 | 1060 | 重合 | 430 | 2 | 500 | 900 | 1220 | 40 | 760 | 840 | 330 | 22 | 200 | 295 | 335 | 150 | 240 | 280 | 8-23 | 8-23 | 4-25 |
| 200ZX350-65 | Y315S-4 | 110 | 1000 | 1860 | 2452 | 230 | 430 | 1180 | 1270 | 重合 | 430 | 2 | 535 | 935 | 1255 | 40 | 760 | 840 | 330 | 22 | 200 | 295 | 335 | 150 | 240 | 280 | 8-23 | 8-23 | 4-25 |
| 250ZX550-32 | Y280S-4 | 75 | 1000 | 1860 | 2628 | 195 | 875 | 1604 | 1031 | 重合 | 430 | 3 | 470 | 1110 | 1290 | 30 | 760 | 840 | 330 | 35 | 250 | 335 | 370 | 250 | 335 | 370 | 12-18 | 12-18 | 4-25 |
| 250ZX400-50 | Y280M- | | | | | | | | | | | | | | | | | | | | | | | | | | | | |

泵的安装 PUMP INSTALLATION

- 1、在泵与电动机联轴传动时，应注意泵轴与电动机输出的同轴度；泵安装的准确与否对泵的运行平稳性和使用寿命有较大的影响，因此必须仔细认真地安装和校正。
 - 2、泵联轴器必须用螺母紧固好，并锁紧螺母，谨防螺母松动，否则易引起叶轮窜动，造成机械故障。
 - 3、为使泵体内能够保持一定的储存液，以达到较好的自吸能力和防止机械密封的干磨擦，必须使泵的进口高于泵轴中心线。
 - 4、吸入管路的安装应注意：
 - A、吸入口的安装高度不能超过3.5米，在条件许可时，吸入口的安装高度应尽可能地低于水池最低储水面，并尽量缩短吸入管的长度，少装弯头，这样有利于缩短自吸时间，提高自吸功能。
 - B、吸入管路中的阀门、法兰等应严防漏气或渗漏液体，即吸入管路不允许有漏气现象存在。
 - C、应防止泵体内吸入固体等杂物，为此吸入管路上应设置过滤器。过滤器的有效过流面积应为吸入管截面的2-3倍，过滤器应定期检查。
 - D、吸入管路和吐出管路应有自己的支架，泵体本身不允许承受管路的负荷。
 - 5、水泵在安装时，应使泵及管路的静电接地电阻达到其规定要求。
 - 6、安装时应严格检查泵壳及管路中有无石块、铁砂等杂物。
 - 7、校正泵联轴器及电动机联轴器的安装间隙及同轴度，其不同轴度允许偏差为0.1毫米。泵轴和电动机轴的高度差可在底脚上垫铜片或铁皮调整。
 - 8、在机组实际运转3-4小时后，作最后检查，如无不良现象，则认为安装已妥，在试运转中应检查轴承的温度，轴承体的温度不宜超过70℃。
 - 9、该泵轴承体凡设有冷却室装置的冷却水接头供配内孔为 $\phi 12$ 的胶管或塑料管之用。其螺纹尺寸为M12 \times 1.5。
 - 10、在泵的出口管路上如装有单向阀而在自吸过程中不能使泵顺利地排出气体时，应在泵的出口处加接排气小管及阀。
1. With the shafts of both pump and motor linked in action, pay attention to the concentricity between the pump shaft and the motor's output; and carefully mount and calibrate the pump as which will leave a bigger affection to the running stability and duration of it.
 2. Fasten the nut on the pump's clutch, or the impeller may be made easily movable to cause a mechanical failure.
 3. Have the pump inlet higher than the central line of the pump shaft so as to have a certain volume of liquid kept inside of the pump to get a better self-suction capacity and prevent the mechanical seal from drying friction.
 4. Cautions for the installation of the suck-in pipeline:
 - A. The installation height of the suck-in port shall not be over 3.5m and, if the condition is allowed, lower than the lowest water storing surface as can as possible and make the length of the suck-in pipe as short as possible and the elbow less mounted so as to shorten the self-suction time and enhance the self-suction function.
 - B. The valve, flange etc. inside of the suck-in pipeline shall be prevented from air or liquid leaking, that means no air-leaking is allowed inside of it.
 - C. To prevent any solid etc. impurities from sucking into the pump, a filter should be set on the suck-in pipeline, with the effective filtering area 2-3 times the section of the pipeline and the filter checked in a periodic time.
 - D. Get both suck-in and vomiting pipelines a stand of their own and do not let the pump bearing any pipeline.
 5. During installation of the pump, make the static grounding resistance of it and the pipeline up to the set requirement.
 6. Check if there is stones, iron sand or any other impurity inside of the pump casing and the pipeline in installation.
 7. Calibrate the installation space and the concentricity between the clutches of both pump and motor, with the allowed deviation of the concentricity at 0.1mm, and put a copper or iron sheet under the foot to adjust the height difference between the shafts of both pump and motor.
 8. Take a final check after the unit actually runs for 3-4h and it is deemed for the installation to have been well done if non-bad condition. Check the bearing temperature during trial, which shall not be over 70℃.
 9. For the bearing body of the pump set with a cooling room, use a rubber or plastic pipe of a 12mm diameter inner hole to fit the cooling liquid union, the thread size is M12x1.5.
 10. When the pump can not successfully exhaust the air during the self-suction process due to an one-way valve which is mounted on the outlet pipeline of it, set a small exhaust pipe and valve at the outlet.

泵的使用 USE OF THE PUMP

(一) 起动前的准备及检查工作

- 1、本系列自吸泵，根据泵的工作运转状况，分别采用优质钙基黄油和10号机油进行润滑，如果采用黄油润滑的泵应定期向轴承箱内加注黄油，采用机油润滑的泵，如果油位不足，则加足之。
- 2、检查泵壳内的储液是否高于叶轮的上边缘，如若不足，可以从泵壳上的加液口处直接向泵体内注入储液，不应在储液不足的情况下启动运转，否则泵不能正常工作，且易损坏机械密封。
- 3、检查泵的转动部件是否有卡住磕碰现象；检查泵体底脚及各联结处螺母有无松动现象；检查泵轴与电动机主轴的同轴度或平行度；检查进口管路是否漏气，如有漏气，必须设法排除；打开吸入管路的阀门，稍开(不要全开)出口控制阀。

(二) 起动及操作

- 1、起动自吸泵，注意泵轴的转向是否正确；注意转动时有无不正常的声响和振动。
- 2、注意压力表及真空表读数，起动后当压力表及真空表的读数经过一段时间的波动而指定稳定后，说明泵内已经上液，泵进入正常输液作业。在泵进入正常输液作业前即自吸过程中，应特别注意泵内水温升高情况，如果这个过程过长，泵内水温过高，则停泵检查其原因。
- 3、如果泵内液体温度过高而引起自引困难，那行可以暂时停机，利用吐出管路中的液体倒流回泵内或向泵体上的加储液口处直接下来向泵内补充液体，使泵内液体降温，然后起动即可。
- 4、泵在工作过程中如发生强烈振动和噪声，有可能是泵发生汽蚀所致，汽蚀产生的原因有两种：一是进口管流速过大，二是吸程过高。流速过大时可调节出口控制阀，升高压力表读数，在进口管路有堵塞时则应及时排除；吸程太高时可适当降低泵的安装高度。

Preparations and checks prior to starting

1. According to the running states, this series self-suction pumps are lubricated with quality calcium-based grease and 10# engine oil separately. For those lubricated with grease, fill grease into the bearing box in a periodic time and, for those with engine oil, fill it fully when the oil level is insufficient.
2. Check if the stored liquid inside of the pump casing is above the upper edge of the impeller and, if not, prime liquid directly from the filling port on the casing. Do not start the pump in case of an insufficient stored liquid, or the pump would not work normally and the mechanical seal would be easily damaged.
3. Check if the moving parts of the pump are jammed or collided; if the foot on the pump bottom and the nuts on the joints are loose; check the concentricity or the parallelism between the shafts of both pump and motor; check if there is air-leaking with the inlet pipeline and settle it if any; open the valve on the suck-in pipeline and slightly open (not fully) the outlet control valve.

Start and operation

1. Pay attention to the pump shaft to see if it moves in the correct direction when to start the self-suction pump; and if there is abnormal sounds and vibration when it moves.
2. Pay attention to the readings on both pressure gauge and vacuum meter, when the indications of which get stable after a periodic time fluctuation after the pump is started, that means liquid has been primed into the pump and the pump gets into the normal liquid transportation. Before the pump gets into the normal liquid transportation, e.g. During the self-suction process, pay special attention to the temperature rise of the liquid and stop the pump to check the cause if this process is too long and the temperature is so caused too high.
3. Temporarily stop the pump in case of a difficult self-suction caused due to too high liquid temperature and make it lower by means of the back flow into the pump of the liquid in the vomiting pipeline or supplementing liquid directly from the filling port on the pump casing, then start the pump again.
4. It is possible for an air erosion to occur with the pump that causes a severe vibration and noise during the work of the pump and the air erosion occurs with two causes: one is too quick flow rate in the inlet pipe and the other is too high suction travel. For the former, adjust the outlet control valve, raise the reading on the pressure gauge and remove it in case of block-up in the inlet pipeline; for the latter, properly lower the pump's installation height.

ZX系列自吸泵

5、泵在工作过程中因故停泵，需再启动时，出口控制阀应稍开(不要全开)，这样既有利于自吸过程中气体从吐出口排出，又能保证泵在较轻的负荷下启动，同时，注意检查管路系统有无渗漏现象。

(三)停泵

- 1、首先必须关闭吐出管路上的阀门。
- 2、使泵停止转动。
- 3、在寒冷季节，应将泵体内的储液和轴承体冷却室内的水放空，以防冻裂机件。

5. When the pump is stopped because of something during work and started again, slightly (not fully) open the outlet control valve. This is benefit for the air to be exhausted on-time from the vomiting port during the self-suction process and also ensures the pump is started with a lighter load. Meanwhile, pay attention to checking if there is a leak from the pipeline system.

Stop

1. First close the valve on the vomiting pipeline.
2. Have the pump stopped running.
3. In cold seasons, drain out the liquid stored inside of the pump casing and the water inside of the bearing's cooling chamber completely to prevent any parts from being frozen to crack.

泵的维护和拆装 MAINTENANCE, DISASSEMBLY AND ASSEMBLY OF THE PUMP

该泵的特点是结构简单可靠，经久耐用。在泵正常情况下，一般不需要经常拆开保养。当发现故障后随时给予排除即可。

(一)维护该泵时应注意

当泵长期运行后，滚动轴承，前、后密封环磨损到一定程度时，须进行更换；机械密封在不漏液的情况下，一般不应拆开检查。若轴承体下端泄漏口处产生严重泄漏时，则应对机械密封进行拆检。装拆机械密封时，必须轻取轻放，注意配合面的清洁，保护好静环和动环的镜面，严禁敲击碰撞。因机械密封而产生泄漏的原因主要是磨擦付镜面拉毛所致。其修复办法，可对磨擦付端面进行研磨使恢复镜面。机械密封产生泄漏的另一原因是“O”形橡胶密封圈(或缓冲垫)安装不当，或者变形老化所致。此时则需调整或更换“O”形密封圈进行重新装配。

(二)泵拆装顺序

- A、拆下电动机或脱出联轴器。
- B、拆出轴承体总成，检查叶轮和前口环的径向间隙，检查叶轮螺母有无松动。
- C、拆下叶轮螺母，拉出叶轮，检查叶轮和后密封环的径向间隙。
- D、松出机械密封的紧定螺钉，拉出机械密封的动环部分，检查动、静环端面的贴合情况，检查“O”形密封圈(或缓冲垫)的密封情况。

This pump features a simple and reliable structure, durability and is generally unnecessary to be disassembled often for maintenance if working normally. Troubleshoot it in case of a failure.

Cautions at maintenance

When the rolling bearing and both front and rear seal rings are worn out to a certain degree after a long time running of the pump, replace them; the mechanical seal does not need to be removed for a check provided that no liquid leak with it while does when there is a serious leak from the leaking port on the lower side of the bearing. Take care of the mechanical seal during disassembly and assembly, clean the fitted face, properly keep the mirrors of both static and dynamic rings and do not knock on them and get them collided, as the cause for the leaking of it is mainly at the burrs on the frictional pair mirrors. To repair it, grind the mirrors to have it recovered. Another cause for the mechanical seal to leak is the “O”-type rubber seal ring (or buffering gasket) improperly mounted or deformed or aged, then adjust or replace it.

Pump disassembly and assembly sequences

- A. Remove the motor or take out the clutch.
- B. Remove the bearing assembly, check the radial space between the impeller and the front oral ring and check if the impeller nut is loose.
- C. Screw out the impeller nut, pull out the impeller and check the radial space between the impeller and the rear seal ring.
- D. Loosen the fixing screw on the mechanical seal, pull out the dynamic ring and check the fitting state between the end-faces of both static and dynamic rings and the sealing state of the “O”-type seal ring (or the buffering gasket).

ZX系列自吸泵

- E、旋出联轴器的紧定螺母，拉出联轴器。
F、拆下轴承端盖，拆出泵轴和轴承。
G、安装时以相反顺序进行装配即可。

- E. Screw out the fixing nut on the clutch and pull out the clutch.
F. Remove the end cover on the bearing to remove both pump shaft and bearing.
G. Take reversed sequences for assembly.

常见故障原因及解决方法 FAILURES, CAUSES AND TROUBLESHOOTING

| 故障 Failure | 原因 Causes | 解决办法 Troubleshooting |
|--|--|--|
| 1、水泵不出水 1. No water out of pump | a、泵壳内未加储液或储液不足 b、吸入管路漏气 c、转速太低 d、吸程太高或吸入管路过长 e、机械密封泄漏量过大 f、吸入管路气体不能从出口排出 a. No or insufficient liquid stored inside of pump casing b. Air leaks from suck-in pipeline c. Too slow speed d. Too high suction travel or too long suck-in pipeline e. Too severe leakage from mechanical seal f. Air inside of suck-in pipeline unable to be exhausted from the outlet | a、加足储液 b、检查并排除漏气现象 c、调整转速 d、降低吸程或缩短吸入管路 e、修复或更换 f、打开出口阀门，使气体排出 a. fill sufficient liquid b. check and settle the air leak c. adjust the speed d. lower suction travel or shorten suck-in pipeline e. repair or replace it f. open the outlet valve to let air out |
| 2、杂音和振动较大 2. Bigger noise and vibration | a、底脚不稳 b、泵轴弯曲 c、汽蚀现象 d、轴承磨损严重 e、进口管路内有杂物 f、泵与电动机两者主轴不同心 a. Foot unstable b. Pump shaft bent c. Steam erosion d. Bearing seriously worn out e. Impurities exist inside of inlet pipeline f. Shafts of both pump and motor is not concentric | a、加固 b、更换或校正 c、调整工况 d、更换轴承 e、清除杂物 f、调整同轴度 a. Solidify it b. Replace or correct it c. Adjust working conditions d. Replace it e. Get rid of impurities f. Adjust them to be concentric |
| 3、出水量不足 3. Insufficient water-out quantity | a、杂物进入吸入管或叶轮流道堵塞 b、转速太低 c、叶轮或叶轮密封磨损严重 a. Impurities get into suck-in pipe or impeller gear blocked up b. Too slow speed c. Impeller or impeller seal seriously worn out | a、排除堵塞物 b、调至额定转速 c、更换口环 a. Get rid of impurities b. Adjust the speed to the rated one c. Replace oral ring |
| 4、轴功率消耗过大 4. Too big consumption of shaft power | a、流量过大 b、转速太高 c、泵轴弯曲或叶轮卡碰 d、泵内流道堵塞或被卡住 a. Too heavy flow b. Too quick speed c. Pump shaft bent or impeller jammed or collided d. The gear inside of the pump blocked-up or jammed | a、升高出口压力 b、适当降低 c、更换或校正 d、排除堵塞物 a. Raise the outlet pressure b. Properly lower it c. Replace or correct d. Get rid of blocking matters |

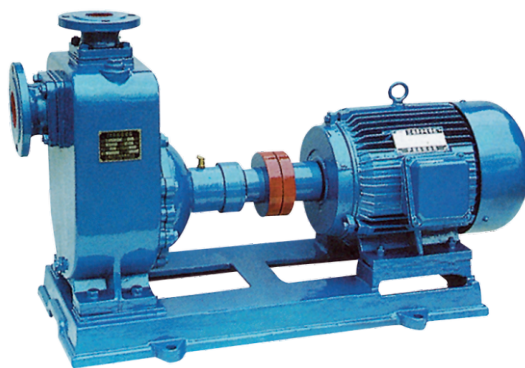
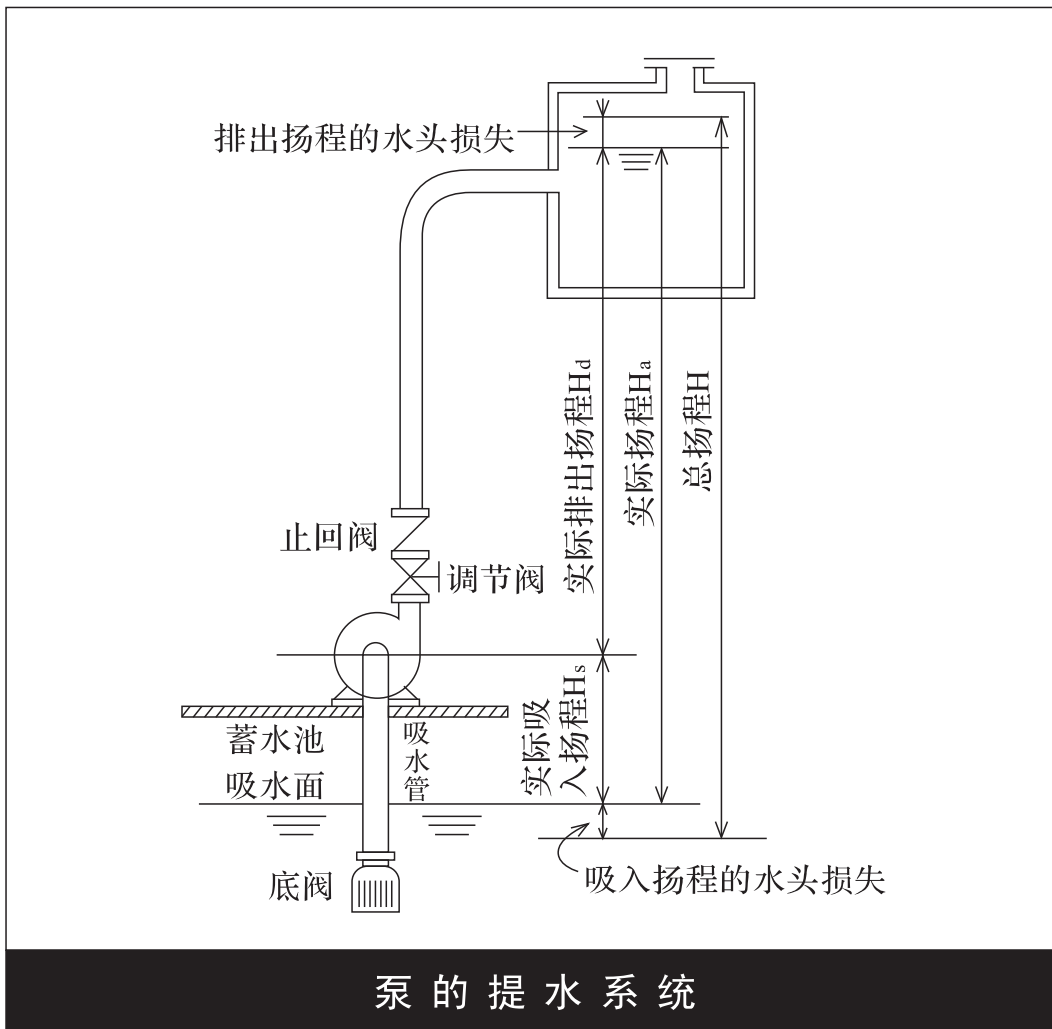

ZX系列自吸泵

上海河山泵业有限公司

Shanghai Heshan Pump Co., Ltd.

地址：上海市闸北区共和新路2999号

总机：+86-21-56557777

传真：+86-21-51685999

免费热线：800 820 0075